

USER MANUAL OF Ex ELECTRIC MOTOR FOR POTENTIALLY EXPLOSIVE ATMOSPHERES

GENERAL INTRODUCTION

Seipee S.p.A. produces electric motors according to Low Voltage Directive 2006/95/CE; EMC Directive 2004/108/CE; in particular some motor series listed below, are produced in compliance with the Directive about devices and protection systems for use in potentially explosive atmospheres ATEX 2014/34/EU **group II category 3D/3G, zone 2 and zone 22**.

The motor series of the ATEX category are:

SERIES	HOUSING MAX TEMP. FOR 3G MOTORS	HOUSING MAX TEMP. FOR 3D MOTORS	FRAME SIZE (mm)
AX	T3 / T4	135 °C	50-132
JM	T3 / T4	135 °C	56-160
JMD	T3 / T4	135 °C	80-160
GM	T3 / T4	135 °C	160-315
GMD	T3 / T4	135 °C	180-250

Verifying the motor suitability for the classification and the characteristics of the flammable substances in the area where the motor is placed, is full responsibility of the product user.

The following tables show some definitions:



CATEGORY 3	It includes equipment designed to operate in conformity with the operating parameters established by the manufacturer and ensuring a normal level of protection; These motors can be used only in classified zones 2 and 22.
CATEGORY 2	It includes equipment designed to operate in conformity with the operational parameters established by the manufacturer and ensuring a high level of protection (even in the event of frequently occurring disturbances or equipment faults); these motors can be used only in both classified zones 1 / 21 and 2 / 22.
CATEGORY 1	It includes equipment designed to operate in conformity with the operational parameters established by the manufacturer and ensuring a very high level of protection (even in the rare event of incidents related to equipment. The level of protection is guaranteed even the event of two faults occurring independently) These motors can be used in classified zones 0/20, 1/22 or 2/22.

ZONE		MOTOR CATEGORY		DESCRIPTION
GAS	DUST	GAS	DUST	
0	20	1G	1D	SEE CATEGORY 1
1	21	2G	2D	SEE CATEGORY 2
2	22	3G	3D	SEE CATEGORY 3



TEMPERATURE CLASSES					
T1	T2	T3	T4	T5	T6
450 °C	300 °C	200 °C	135 °C	100 °C	85 °C

Calculation of the flash points for combustible dusts	
CLOUD OF DUSTS	T_IGNITION * 2/3
LAYERS OF DUSTS	T5mm – 75k

The following table is just indicative, for a more exhaustive explanation refer to the CEI EN 60079-0.

Category 3	It includes equipment designed to operate in conformity with the operating parameters established by the manufacturer and ensuring a normal level of protection; these motors can be used only in classified zone 2 and 22.	
Marcatura ATEX motori SEIPEE	 II 3G- Ex ec IIC T3 Gc	II = equipment group (for surface installation); 3 = equipment category (see table); D = dusts; G = gases; 135 °C, T3 o T4 = Max temperature on the motor chassis/housing; IP65 = degree of protection; IIC/IIC = Equipment group subdivision depending on the type of dust o gas; Gc/Dc = Equipment Protection Level (EPL).
	 II 3G- Ex ec IIC T4 Gc	
	 II 3D- Ex tc IIC T135 °C Dc IP65	

When the motors are allowed to be used into classified area Zone 2 and Zone 22, they have only one nameplate with 2 different markings for the different type of protection.

GENERAL WARNINGS	
	Before starting the electric motor, read carefully these instructions and the technical data reported on the nameplate of the electric motor. It is very important to use the motor for the purposes for which it was built. Use the electric motor only for the intended uses and expected environmental conditions. The motors for explosive atmospheres are normally expected to operate with ambient temperature -20°C ÷ +40°C and up to 1000m above sea level; for different operating values, contact our technical department. The incorrect use or small modification to the motor can compromise protection level, safety and reliability of the motor. Non-observance of the following instructions or lack of maintenance of the motor, may compromise safety and thus prevent the use of the motor in dangerous areas.
	The motor is equipped with appropriate temperature sensors in order to avoid exceeding of temperature according to the class indicated on the nameplate. Provide a ground connection by means of the power cable and the corresponding terminal. Make an equipotential circuit between the main chassis of the machine and the other machines or containers connected to it. All personnel involved in the installation, operation and maintenance procedures must be qualified, aware of these instructions and with full knowledge of the general regulations and those concerning explosive atmospheres. All operations on the motor must be done while the machine is off (including any auxiliary components); insure against the possibility of unintentional reconnection.



DO NOT OPEN THE MOTOR AND/OR THE TERMINAL BOX COVER IN POTENTIALLY EXPLOSIVE ATMOSPHERES. To minimize the danger caused by static electricity, clean the motor only with a damp cloth or other tools that do not cause friction. Use naked flames, smoke and hot gases close to the motors during their operation is strictly prohibited.
Be careful at synthetic clothing that may generate electrostatic discharge; use anti-static clothing and shoes.

INSTALLATION AND HANDLING

General information: When receiving the motor, make sure that it matches the characteristics of the purchase order and it is not damaged; in that case notify immediately to the person who is making the delivery. Verify all the nameplate data and check the suitability for the required application before using the motor. Do not use damaged motors or not suitable for the application. If available, lift the motor using lifting lugs, which are suitable only for lifting the single motor. Store in a clean, covered, dry place and between -15°C and +40°C. Avoid direct contact of the motor with the ground and corrosive agents.

Installation: clean carefully the motor: remove packaging and eventual protective products, paying attention to not damage the seals. If the motor has been stocked for a long time, check the insulation resistance before commissioning paying attention to not operate in an explosive atmosphere. It is recommended to ensure correct air circulation for the electric motor on the fan side and appropriate heating exchange with the surrounding environment. Keep the motor away from sources of heat, fix it on a solid and leveled base in order to avoid harmful vibrations during operation. Protect the motor from possible falls of material from above in the case the position of the motor could damage the fan.

Connections and commissioning: The motors are provided with Ex certified cable glands with degree of protection greater than or equal to the protection of the motor. The cable glands must be tightened to ensure the strength and tightness of the terminal board. Unused inputs must be closed with Ex certified caps. The motors are equipped with terminal block for connection to the cable lug. Further information about cable glands and plugs are reported in the **general catalog or you can contact Seipee SpA technical department**. The motors are equipped with a terminal block with 6 terminals for connection to the cable lug (use cable ends suitable for the cable cross-section).

Single speed motors (series JM, GM) can be connected in star or delta connection on the terminal block and powered directly from the mains (voltage information and connection type are written on the nameplate). Pay attention to the wiring diagram of double speed motors (series JMD, GMD) as different from standard single-speed motors. Connection diagrams for standard motors are given below, while information for special connections are provided inside the terminal box. The diagrams below can also be found on the back of the terminal box cover or in the **Seipee general catalog**. For special motors different from these listed below, please refer to the diagram on the back of the terminal box cover, or contact the technical department of Seipee SpA.

Wiring diagrams for the power supply of Ex motor series AX, JM and GM



Wiring diagrams for the power supply of Ex motor series JMD and GMD



All electrical connections must be integral with the terminal block to avoid loose electrical connections. Air distances between non-insulated powered parts and ground must be more than 6 mm. In addition to the winding terminals and the ground terminal, the terminals for the use of thermal probes PTC thermistors are inside the terminal box; thermal sensors are identified by adhesive labels positioned inside the terminal box near the sensor or on the cables of the sensor. For the management of PTC thermistors it is necessary to use a dedicated device with a relay (appropriately calibrated according to the maximum surface temperature written on the plate) that can interrupt the power supply to the motor, in compliance with the essential safety requirements of European Directive 2014/34/EU Annex II 1.5.1. This device must be installed outside potentially explosive atmosphere areas. The reactivation of the release device should only occur manually and not automatically. Depending on the series, the motors are equipped with one or two terminal grounds: one inside the terminal box and/or one external to the housing. It is recommended to connect the ground wire or protection wire to the motor terminal ground with the printed symbol. The connection of the ground wire must be performed according to EN60079-0 with minimum cross-section as below:

S = Section of the phase conductor in [mm ²]	T = Minimum cross-section of the grounding conductor in [mm ²]
$S \leq 16\text{mm}^2$	$T = S$
$16 < S \leq 35\text{mm}^2$	$T = 16\text{mm}^2$
$S > 35\text{mm}^2$	$T \geq 0,5 S$

The power cables must be suitable to withstand the environmental and operating conditions of the motor.

Motors for explosive atmospheres must be protected against overloads with automatic power supply disconnection by a thermo-magnetic circuit breaker and/or by a device for direct temperature control with thermal sensors fixed on the winding.

Cooling system: standard motors are supplied with IC411 cooling method.

In case of IC418 cooling method, make sure it complies with the limits of maximum temperature declared on the nameplate of the motor, both in respect of the explosive atmosphere in which motors are installed and to prevent any damage to the motor.

In the case of IC410 cooling method (motor without fan), the motor is de-rated in power by 50% for S1 duty respect to the standard S1 output power in version IC411 (self-ventilated motor).

In case of IC416 forced ventilation, cooling is provided by an auxiliary system with independent power supply which must also be certified Ex and equipped with specific ATEX marking. The user must provide a safety device that allows the start of the main motor only when the auxiliary motor of the forced ventilation is in

operation. About the connection diagram, refer to the section “connections and commissioning – AX, JM and GM series” of this instructions of use and maintenance.

Motors with encoder: Ex-certified components are supplied in case of encoder option, and both instructions for wiring connection and the special connector for the wiring to the external devices are provided with the motor.

Motors supplied by an inverter: this type of power supply involves voltage and current signals which are not purely sinusoidal with a consequent increase in losses and more heating with respect to the motor directly connected to the main supply. Moreover by varying the speed with an inverter also the ventilation flow varies (case IC411) causing, for low speed, more heating of the motor respect to the rated speed of the nameplate. For these reasons, **the performance declared for main supply operation cannot be kept unchanged if powered by an inverter. Performance of the motor will be higher or lower depending on the type of inverter and its performance control; therefore, the user must check the performance of the motor powered by the chosen inverter in order to ensure the correct thermal performance of the motor. Temperature sensors (PTC thermistors) are provided inside the motor,** in order to ensure the limits of the declared temperature class. Especially **in case the temperature class of the motor is T4 (135°C), the user must connect the thermal sensors** (for example PTC thermistors) to a release device in order to ensure the interruption of power supply if dangerous temperature is reached. The recovery of the release device must be done only manually and not automatically (in full compliance with the safety requirements set by the Directive ATEX 2014/34/EU Annex II point 1.5). According to the local regulations where the motor is installed, it may be possible to connect the temperature sensors (PTC) to some equipment different from the release device described: for example, may be connected to the inputs of the inverter, etc...).

Three-phase asynchronous motors powered by main supply follow emission limits and immunity regulated by the standards of electromagnetic compatibility. In case of inverter supply, the technician is responsible for the motor and inverter installation into the machine, and also to comply with the limits of immunity and emission data by the reference EMC standards. The choice of the type of inverter should be made taking into account that the motors are suitable for a rated voltage less than 500V, peak voltage of 1000V and voltage gradient less than 1kV/μs; higher values would reduce the life of the winding insulation. Moreover, the value of the voltage peaks is also influenced by the length of the power cable.

When the motor is provided with auxiliary ventilation (IC416), the information written in paragraph “cooling system” must be respected.

Commissioning for variable speed applications must be performed according to: the following instructions, the technical catalogue and technical manuals of the inverter as well as national regulations. All parameters needed for setting the inverter can be taken from the motor nameplate or from the technical catalogue according to the type of inverter (rated voltage, rated current, rated frequency, rated speed, number of poles, rated power). **In case of missing or inaccurate information, do not activate the motor before ensuring correct settings.**



It is recommended the use of all safety functionalities provided by the inverter software to improve the application safety. These information complement, but do not replace, safety functions required by the Directives and the Regulations.

MAINTENANCE

Periodic maintenance: Standards EN60079-17 and EN60079-19 about the repair and maintenance of electrical equipment in hazardous areas must be respected. Only experienced people and with a perfect knowledge of these standards should handle this type of equipment. Maintenance operations must be carried out in complete safety: not running motor, disconnected from the power supply and away from potentially explosive atmosphere areas.

It is important to check the motor at regular intervals. Keep the motor clean and ensure a good ventilation. Periodically remove dust layers, which may be deposited on the external parts of the motor. If the motor is used in a dusty environment, the ventilation system must be regularly checked and cleaned in order to prevent the motor from overheating due to the obstruction of the normal cooling cycle. Check the condition of the seals and grease them periodically, as these components are in contact with moving parts and wear out quickly. If necessary, replace seals with the same or equivalent type to the original one mounted on the motor. When replacing the seals lightly grease the sliding area. Check that the motor runs without vibrations or unusual noises. If there are vibrations, check the motor base and balance of the coupled device. All bearings mounted on series AX, JM and JMD are lubricated for lifetime and just need to be simply replaced at the end of their working lifetime. Bearings mounted on series GM and GMD can be either lubricated for lifetime (same as for series AX, JM and JMD) or may require lubrication at regular intervals (only use good quality lithium lubricants suitable for bearings, see label about lubrication intervals placed on the motor or refer to the technical catalogue or contact our technical department for further information). Bearings lifetime changes considerably depending on the type of loads and starts that are applied to the motor and it also depends on the temperature and humidity of the working environment. For all details about bearings, lubrication and applied loads, refer to the general technical catalogue or contact our technical department. Excessive noise usually indicates the need to replace the bearings. If commissioning operations have been carried out recently, check first the coupling with the load and correct the possible misalignment. If the bearings are still noisy, it means that they are already damaged and must be replaced. When replacing the bearings, pay attention not to damage the windings while removing the rotor from the stator. The bearings must be removed with the use of an extractor. For assembling the bearings use a press with suitable tools on the inner ring, or preheat the bearing itself to about 80°C and place it on the shaft. Make sure that the inner ring is properly supported on the shaft and that the bearings are replaced with the same or equivalent type of the original ones. When bearings are replaced, the seals on the shaft must also be replaced with the same quality and characteristics of the original ones. **Check the correct electrical terminals tightening, fastening and coupling of the mechanical systems. In case of disassembling and reassembling of the motor where mastic and/or silicone protection are present, scrape and clean accurately the surface and provide some degree of protection during assembly using mastic type LOXEAL 5920, which has properly characteristics of minimum safety (operating temperature -55°C to +180°C). Eliminate possible surface layers of dust during reassembly.**

Regarding thermal sensors fixed on the motor, refer to the following table:

Motor  II 3G- Ex ec IIC T3 Gc	Thermal sensor PTC 150°C
Motor  II 3G- Ex ec IIC T4 Gc	Thermal sensor PTC 130°C
Motor  II 3D- Ex tc IIIC T135°C Dc IP65	Thermal sensor PTC 150°C



Motors of series GM and GMD have condensation drain holes (refer to the picture below for their position) or holes for auxiliary lifting ringbolts supplied with closed holes, while on series JM and JMD holes are only made on request. In case of environments where there may be condensation inside the motor, it is necessary to open periodically the drain holes, in order to ensure their functionality and avoiding winding damaging; when draining operations are finished, the holes must be closed using mastic LOXEAL 5920. Perform all these operations only when the power is off, in a clean environment and away from potentially explosive atmospheres.

MAKE SURE TO CLOSE DRAIN HOLES AND/OR THE HOLES FOR AUXILIARY LIFTING RINGBOLTS, USING THE REMOVED GRUB SCREW AND APPLYING MASTIC LOXEAL 5920 ON THE THREAD OF THE GRUB SCREW.

When operations are finished, drain holes or holes for auxiliary lifting ringbolts must be reclosed, otherwise the security method indicated on the nameplate is compromised.

Condensation drain holes for standard execution of motor series GM, GMD

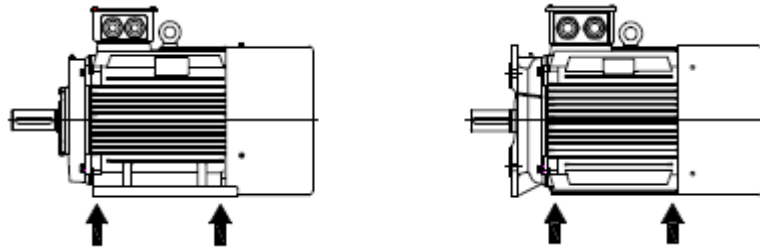

Condensation drain holes for special execution of motor series GM, GMD

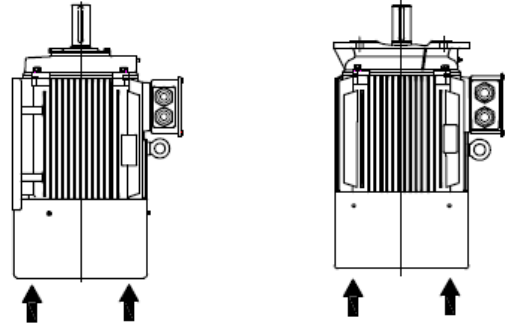
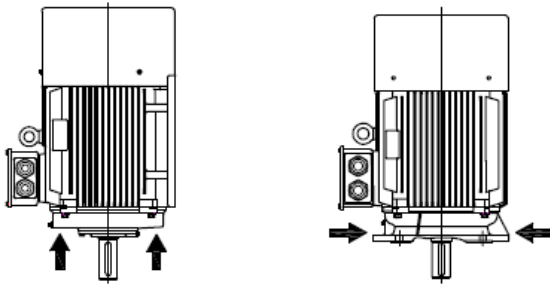

Repairing: Repairing of motors for explosive atmospheres must be made according with the criteria specified in the standard EN60079-19. Any operation must be performed by Seipee SpA.

 **Disposal:** in case of disposal do not dispose in the environment, but comply with current regulations in the country of sale.