

HEAVY LOADS

BALLCAGE SEMI-TELESCOPIC SLIDES SR.-SR..D. SERIES

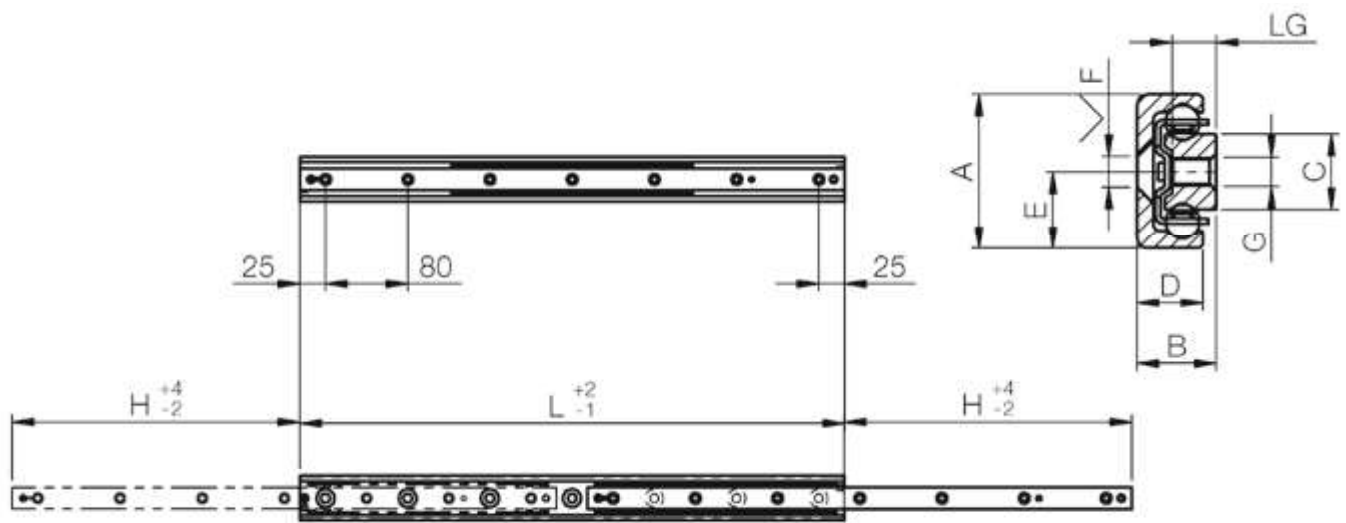

Code	A (mm)	B (mm)	C (mm)	D (mm)	E (mm)	G (mm)	LG (mm)	F (mm)
SR28	28	13	14,5	11,5	14	M5	6	Ø 5,5 for screw M5 DIN7991
SR35D	35	17	16	15,7	17,5	M6	7	Ø 6,5 for screw M6 DIN7991
SR43	43	22	21	18,3	21,5	M8	11,5	Ø 8,5 for screw M8 DIN7991

SR semi-telescopic slides allow for half of its length's extension to one or both sides. The SR28/43 are with a small ball-cage limit stroke screw, that needs to be taken out in case both side extension is requested. SR35 is without this screw.

Load Capacity based on single rail

ORDER CODE	VERSION	CHARACTERISTICS
SR43-1010	BASIC	Cold drawn steel rails with patented "T RACE-NOX 1.0" ; high depth nitride hardening and black oxidation treatment. The rails are cut to size after treatment, so the rail ends are protected by protective spray. All threaded holes are without treatment. Ball-cages in zinc plated steel, while balls hardened steel.
SR43-1010-KL	KL	As a basic TSQ product but with additional black "T RACE e-coating 1.0" on the rails, for high corrosion resistance (min 700 hours resistance in salt fog) . The rail has no T RACE e-coating on the raceway contact area with the rollers, as masked before the treatment. The raceways are anyhow with standard oxidation while the wipers with incorporated pre-oiled felt assure lubrication and corrosion protection of raceways.
SR43-1010-KB	KB	As the version KL but with the ball-cages made in stainless steel AISI304 and the balls in hardened AISI440C

Code	L (mm)	H (mm)	Dynamic coefficient C (N)	Capacity load					Weight (kg)
				Co _{rad} (N)	Co _{ax} (N)	M _x (Nm)	M _y (Nm)	M _z (Nm)	
SR28-130	130	66	872	639	374	13	15	27	0,20
SR28-210	210	119	1544	1139	665	23	46	80	0,35
SR28-290	290	163	2217	1639	958	33	94	161	0,55
SR28-370	370	207	2891	2140	1251	43	158	270	0,70
SR28-450	450	242	3934	2949	1724	55	260	446	0,85
SR28-530	530	285	4607	3450	2017	65	361	618	1,00
SR28-610	610	320	5666	4276	2499	78	510	873	1,15
SR28-690	690	364	6337	4774	2791	88	648	1109	1,30
SR28-770	770	399	7403	5608	3278	100	843	1443	1,45
SR28-850	850	443	8072	6105	3569	110	1018	1742	1,60
SR28-930	930	477	9142	6943	4059	122	1259	2154	1,75
SR28-1010	1010	521	9810	7438	4348	132	1471	2516	1,90
SR28-1090	1090	565	10480	7934	4638	142	1699	2906	2,05
SR28-1170	1170	600	11550	8774	5129	155	2007	3433	2,20

Code	L (mm)	H (mm)	Dynamic coefficient C (N)	Capacity load					Weight (kg)
				Co _{rad} (N)	Co _{ax} (N)	M _x (Nm)	M _y (Nm)	M _z (Nm)	
SR35D-210	210	121	1,574	1,128	651	31	47	82	0,7
SR35D-290	290	153	3,110	2,306	1,331	51	129	223	1
SR35D-370	370	197	4,043	3,000	1,732	66	216	374	1,3
SR35D-450	450	241	4,976	3,694	2,133	81	326	565	1,6
SR35D-530	530	273	6,602	4,968	2,868	101	507	878	1,9
SR35D-610	610	317	7,532	5,660	3,268	116	669	1,159	2,1
SR35D-690	690	361	8,464	6,352	3,667	131	854	1,479	2,4
SR35D-770	770	393	10,114	7,653	4,419	150	1,135	1,966	2,7
SR35D-850	850	437	11,042	8,342	4,816	165	1,372	2,376	3
SR35D-930	930	481	11,971	9,031	5,214	180	1,631	2,825	3,3
SR35D-1010	1010	513	13,633	10,346	5,973	200	2,012	3,485	3,5
SR35D-1090	1090	557	14,559	11,032	6,369	215	2,324	4,025	3,8
SR35D-1170	1170	601	15,486	11,719	6,766	230	2,658	4,604	4,1
SR35D-1250	1250	633	17,154	13,041	7,529	250	3,139	5,436	4,4
SR35D-1330	1330	677	18,079	13,726	7,925	265	3,525	6,106	4,7
SR35D-1410	1410	721	19,004	14,411	8,320	280	3,934	6,814	4,9
SR35D-1490	1490	753	20,677	15,738	9,086	300	4,514	7,819	5,2

Code	L (mm)	H (mm)	Dynamic coefficient C (N)	Capacity load					Weight (kg)
				Co _{rad} (N)	Co _{ax} (N)	M _x (Nm)	M _y (Nm)	M _z (Nm)	
SR43-210	210	114	2232	1497	966	99	75	117	1
SR43-290	290	152	3817	2615	1688	152	176	272	1,4
SR43-370	370	204	4496	3055	1972	187	266	412	1,7
SR43-450	450	242	6107	4197	2709	239	436	675	2,1
SR43-530	530	280	7746	5368	3464	292	647	1003	2,5
SR43-610	610	318	9403	6556	4232	344	901	1396	2,9
SR43-690	690	370	11072	7757	5006	397	1196	1853	3,2
SR43-770	770	408	11693	8138	5253	432	1416	2194	3,6
SR43-850	850	446	13358	9334	6025	484	1781	2759	4
SR43-930	930	484	15030	10538	6802	537	2187	3389	4,4
SR43-1010	1010	522	16707	11747	7582	589	2636	4084	4,7
SR43-1090	1090	560	18390	12962	8366	642	3126	4843	5,1
SR43-1170	1170	598	20076	14180	9152	694	3658	5667	5,5
SR43-1250	1250	636	21764	15401	9941	747	4231	6556	5,9
SR43-1330	1330	688	22347	15743	10161	782	4637	7184	6,3
SR43-1410	1410	739	24032	16960	10947	834	5280	8180	6,6
SR43-1490	1490	777	25719	18180	11734	887	5965	9241	7
SR43-1570	1570	815	27409	19402	12523	939	6691	10367	7,4
SR43-1650	1650	853	29100	20626	13313	992	7460	11557	7,8
SR43-1730	1730	891	30793	21852	14105	1044	8270	12813	8,1
SR43-1810	1810	929	32488	23080	14897	1097	9122	14132	8,5
SR43-1890	1890	981	33053	23403	15106	1132	9713	15048	8,9
SR43-1970	1970	1019	34745	24628	15896	1184	10634	16476	9,3

TECHNICAL CHARACTERISTICS

SR semi-telescopic slides are hardened rails, - patented T RACE NOX 1.0 treatment for high depth nitride hardened with black oxidation, assuring a long lifetime without wear yet maintaining a good corrosion resistance.

High-Tech applications: The SR telescopic slides are used in many High-Tech applications, requiring smooth and play-free run for the full product lifetime, this is not possible with traditional zinc-plated slides.

These are very cost-effective solutions when **Double-Side extension**, to replace more expensive standard telescopic rails with only one side extension.

High Load capacity: As SR slides are only composed of 2 profiles, without any intermediate element, they assure very high load capacities and are practically without any flexion.

Patented T RACE-NOX 1.0 treatment guarantees a constant preload setting during the complete lifetime, unlike traditional zinc-plated ball-cage slides, which very soon have the zinc worn away at the raceway contact points, with the result of much increased play/shaky movements being evident relatively quickly.

Upon request, customized versions with a longer extension or both customized length and stroke can be supplied.

Load Co rad/ax refers to a single slide.

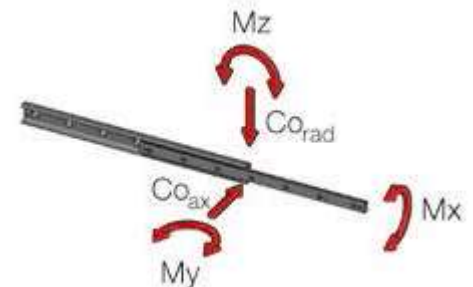

HEAVY LOADS

BALLCAGE SEMI-TELESCOPIC SLIDES SRE SERIES

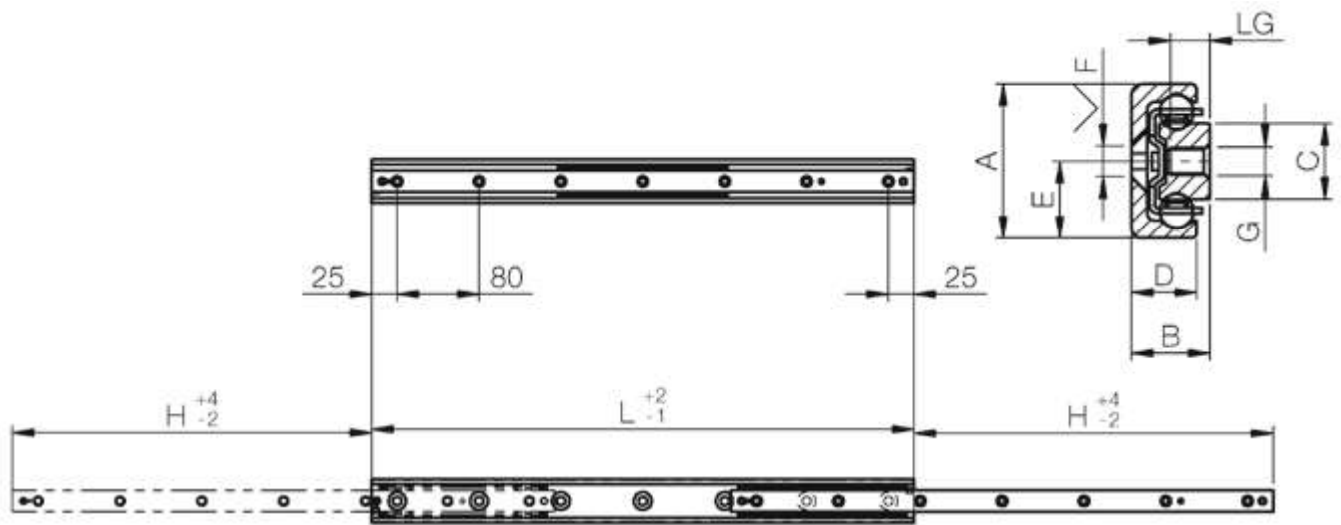

Code	A (mm)	B (mm)	C (mm)	D (mm)	E (mm)	G (mm)	LG (mm)	F (mm)
SRE28	28	13	14,5	11,5	14	M5	6	Ø 5,5 screws M5 DIN7991
SRE35D	35	17	16	15,7	17,5	M6	7	Ø 6,5 screws M6 DIN7991
SRE43	43	22	21	18,3	21,5	M8	11,5	Ø 8,5 screws M8 DIN7991

The SRE semi-telescopic slides allow for about 75% extension of it's length, to both sides.

ORDER CODE	VERSION	CHARACTERISTICS
SRE43-1010	BASIC	Cold drawn steel rails with patented "T RACE-NOX 1.0" ; high depth nitride hardening and black oxidation treatment. The rails are cut to size after treatment, so the rail ends are protected by protective spray. All threaded holes are without treatment. Ball-cages in zinc plated steel, while balls hardened steel.
SRE43-1010-KL	KL	As a basic TSQ product but with additional black "T RACE e-coating 1.0" on the rails, for high corrosion resistance (min 700 hours resistance in salt fog) . The rail has no T RACE e-coating on the raceway contact area with the rollers, as masked before the treatment. The raceways are anyhow with standard oxidation while the wipers with incorporated pre-oiled felt assure lubrication and corrosion protection of raceways.
SRE43-1010-KB	KB	As the version KL but with the ball-cages made in stainless steel AISI304 and the balls in hardened AISI440C

Code	L (mm)	H (mm)	Dynamic coefficient C (N)	Capacity load					Weight (kg)
				Co _{rad} (N)	Co _{ax} (N)	M _x (Nm)	M _y (Nm)	M _z (Nm)	
SRE28-210	210	164	250	164	96	10	8	14	0,4
SRE28-290	290	217	401	264	155	15	18	32	0,5
SRE28-370	370	279	554	366	214	20	33	56	0,7
SRE28-450	450	341	862	575	336	27	62	106	0,8
SRE28-530	530	403	1.017	679	397	32	87	148	1
SRE28-610	610	465	1.172	782	457	37	115	197	1,1
SRE28-690	690	518	1.327	885	517	42	148	254	1,2
SRE28-770	770	580	1.481	988	578	47	185	317	1,4
SRE28-850	850	642	1.803	1.208	706	55	248	425	1,5
SRE28-930	930	703	1.957	1.311	767	60	295	505	1,7
SRE28-1010	1010	765	2.111	1.414	827	64	347	593	1,8
SRE28-1090	1090	818	2.266	1.517	887	69	402	688	2
SRE28-1170	1170	880	2.592	1.741	1.018	77	493	843	2,1

Code	L (mm)	H (mm)	Dynamic coefficient C (N)	Capacity load					Weight (kg)
				Co _{rad} (N)	Co _{ax} (N)	M _x (Nm)	M _y (Nm)	M _z (Nm)	
SRE35D-370	370	281	812	537	310	31	47	82	1,3
SRE35D-450	450	349	1.169	779	450	41	83	144	1,6
SRE35D-530	530	405	1.239	822	475	46	105	182	1,9
SRE35D-610	610	461	1.597	1.065	615	56	156	269	2,1
SRE35D-690	690	529	1.964	1.315	759	66	216	374	2,4
SRE35D-770	770	585	2.026	1.351	780	71	250	434	2,7
SRE35D-850	850	641	2.392	1.600	924	81	326	565	3
SRE35D-930	930	709	2.762	1.852	1.069	91	412	713	3,3
SRE35D-1010	1010	765	2.820	1.886	1.089	96	458	794	3,5
SRE35D-1090	1090	821	3.190	2.137	1.234	106	559	968	3,8
SRE35D-1170	1170	889	3.562	2.391	1.380	116	669	1.159	4,1
SRE35D-1250	1250	945	3.617	2.422	1.398	121	728	1.262	4,4
SRE35D-1330	1330	1001	3.988	2.675	1.545	131	854	1.479	4,7
SRE35D-1410	1410	1069	4.362	2.930	1.692	141	989	1.714	4,9
SRE35D-1490	1490	1125	4.415	2.960	1.709	145	1.061	1.838	5,2

Code	L (mm)	H (mm)	Dynamic coefficient C (N)	Capacity load					Weight (kg)
				Co _{rad} (N)	Co _{ax} (N)	M _x (Nm)	M _y (Nm)	M _z (Nm)	
SRE43-290	290	222	653	430	277	40	33	51	1,3
SRE43-370	370	288	807	530	342	50	53	82	1,7
SRE43-450	450	340	962	631	408	60	78	120	2,1
SRE43-530	530	406	1.485	985	636	81	141	218	2,4
SRE43-610	610	458	1.634	1.081	698	92	179	277	2,8
SRE43-690	690	524	2.184	1.456	940	113	270	418	3,2
SRE43-770	770	590	2.327	1.548	999	123	322	499	3,5
SRE43-850	850	642	2.892	1.934	1.248	144	441	683	3,9
SRE43-930	930	708	3.031	2.022	1.305	154	507	786	4,3
SRE43-1010	1010	760	3.172	2.113	1.364	165	578	895	4,6
SRE43-1090	1090	826	3.740	2.501	1.614	186	734	1.137	5
SRE43-1170	1170	878	3.878	2.589	1.671	196	818	1.268	5,4
SRE43-1250	1250	944	4.453	2.983	1.925	217	1.002	1.552	5,8
SRE43-1330	1330	1010	4.588	3.068	1.980	227	1.101	1.705	6,1
SRE43-1410	1410	1062	5.168	3.466	2.237	248	1.312	2.033	6,5
SRE43-1490	1490	1128	5.301	3.550	2.291	259	1.425	2.207	6,9
SRE43-1570	1570	1180	5.436	3.636	2.347	269	1.542	2.389	7,2
SRE43-1650	1650	1246	6.015	4.033	2.603	290	1.791	2.774	7,6
SRE43-1730	1730	1298	6.148	4.117	2.658	300	1.922	2.977	8
SRE43-1810	1810	1364	6.731	4.518	2.916	321	2.198	3.406	8,3
SRE43-1890	1890	1430	6.863	4.600	2.969	332	2.343	3.630	8,7
SRE43-1970	1970	1482	7.449	5.003	3.229	353	2.647	4.102	9,1

TECHNICAL CHARACTERISTICS

SRE semi-telescopic slides are hardened rails, - patented T RACE NOX 1.0 treatment for high depth nitride hardened with black oxidation, assuring long lifetime without wear and a good corrosion resistance. **SRE Series** offer **75%** extension, while **SR 50%**.

High-Tech applications: The SRE telescopic slides are used in many High-Tech applications, where the SR slides are used in double-pairs for high speed 140-160% extensions both sides, like warehouse pick & place systems, requiring smooth and play-free running for the full product lifetime, - this is not possible with traditional zinc-plated slides.

Cost-Effective: For telescopic applications that requires only 3/4 extension SRE slides are very economical solutions for high load extensions. They are a very cost-effective product when **Double-Side extension**, used to replace more expensive standard telescopic with only one side extension.

High Load capacity: As SRE slides are only composed of 2 profiles, without any intermediate element, they assure very high load capacity and practically zero flexion.

Patented T RACE-NOX 1.0 treatment guarantees a **constant preload setting during the complete lifetime**, unlike traditional zinc-plated ball-cage slides, which very soon have the zinc removed at the raceway contact points, with the resulting situation being quite soon that much increased play/shaky movements is clearly visible. Upon request, customized versions with a longer extension or both customized length and stroke can be manufactured.

Load capacity based on single slide.
Load Co_{rad}/ax refers to a single slide.

