

Please note that we will respond to your individual production requirements and that our **special machines experts** are at your disposal.



	110 kN HPC
Operating pressure	3-6 bar
Press force at 6 bar	110 kN
Approach stroke force at 6 bar	8.4 kN
Return stroke force at 6 bar	6.7 kN
Working stroke, thereof power stroke	50 mm 6 mm
Air-consumption, max. per stroke	26 ltr.
Pneumatic connecting hose	1/2"
Mains supply	90-240 V AC 3A
Control voltage	24 V DC
No. of strokes/min.	30
Weight of lower support	15 kg
Weight	320 kg

Subject to technical modifications.

INFO

Adjustable toggle joint for precise adjustment of the press ram (scaling 0.1 mm)

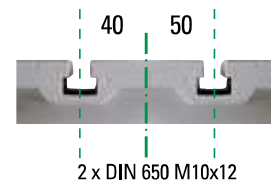

With press force monitoring
Page 32



maXYmos

table Table

On the following pages, you will find detailed descriptions and further illustrations on each topic:

Press force monitoring	Page	32
Lever operating forces and press forces	Page	41
Accessories	Page	42

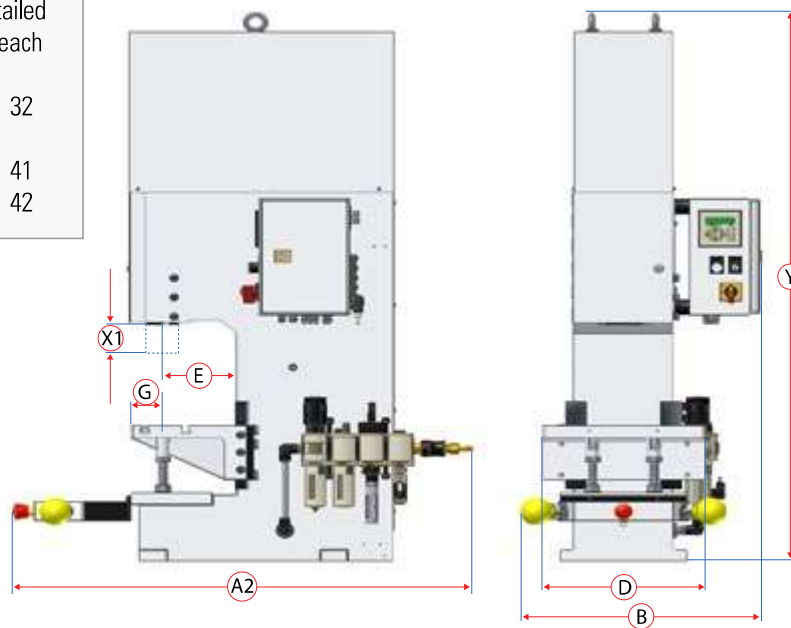

Dimension	110 kN HPC
A2	1010
B	540
D	360
E	160
G	71
Xmax	295
Y	1420
Clamping pivot Ø	
Ø 25 H7	
Clamping pivot length	
45	

Subject to technical modifications.

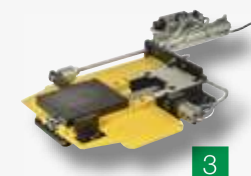

a + b must be ordered separately!

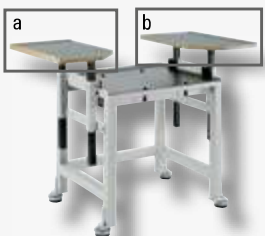

Accessories for your press		Options	Your selection	1 Type 110 kN HPC
X1 = Stroke 50 mm, thereof power stroke 6 mm				X
X1 = Stroke 100 mm, thereof power stroke 6 mm		select one		X
X1 = Stroke 50 mm, thereof power stroke 12 mm				X
X1 = Stroke 100 mm, thereof power stroke 12 mm				X
Special stroke length on request				X
Two-hand safety controls	ZS06			X
Detailed description of the controls, see Page 38		SpiceFlex modular	select one	
1	Rotary table adjustable to segmentations of 2-24, suitable for presses with SpiceFlex control systems			X
	Highly stressable sliding table, mechanical			X
2	Highly stressable sliding table, mechanical with locking bolt		select one	X
3	Highly stressable sliding table with electric control			X
	Press foundation H approx. 700 x W 690 x D 565 mm, adjustable with machine bearing elements			X
4	Press foundation H approx. 800 x W 690 x D 565 mm, adjustable with machine bearing elements		select one	X
	Deposit table for lateral attachment to the press foundation on the left side (a), height adjustable			X
4	Deposit table for lateral attachment to the press foundation on the right side (b), height adjustable		select any	X
	Rotary table changing plate with bores only with RT.			X
5	Footswitch, connected to plug-in connector for SpiceFlex			X
	Clamping pivot without collar		select one	X
6	Clamping pivot with collar			X



X = available